PCI/4711 - PCI/4712 - PCI/4713



WARMING SURFACES WITH INFRARED LAMPS

CONTENTS

1 GENERAL INFORMATION

Purpose of the manual.....	4
Manufacturer and machine identification.....	4
Warming surfaces with infrared lamps description.....	5
Technical specifications.....	5
Overall dimensions.....	5
Safety information.....	6

2 INSTALLATION INFORMATION

Packaging and unpacking.....	7
Installation area.....	7
Electrical connections	7

3 USE AND CLEANING INFORMATION

Control descriptions.....	8
Recommendations for use	8
Warming surfaces with infrared lamps use.....	8
End of the day cleaning	8
Extended periods of disuse	8

4 TROUBLE SHOOTING, RECYCLING

Introduction.....	9
Problems, causes, solutions.....	9
Disposal and recycling.....	9

ATTACHMENTS

Spare parts catalogue
Wiring diagram

Purpose of the manual

This manual was written by the Manufacturer and is an integral part of machine equipment. During design and construction the Manufacturer has carefully considered possible hazards and personal risks that may result from interaction with the machine. In addition to observing the specific laws in force, the manufacturer has adopted all “exemplary construction technique principles”. The purpose of this information is to advise the users to use extreme caution to avoid risks. However, discretion is invaluable. Safety is also in the hands of all the operators who interact with the machine. Keep this manual in a suitable place, always within reach for consultation. The following symbols are included to better stress some passages:

 **DANGER – WARNING:** indicates hazards that may cause serious damages; attention is required.

 **INFORMATION:** indicates particularly important technical information.

The following is enclosed with this manual:

- Warranty certificate describing the Manufacturer’s warranty conditions.
- Documents that prove conformity with effective health and safety laws.

Contact the Authorised dealer for any service request, information or spare parts order.

Manufacturer and machine identification

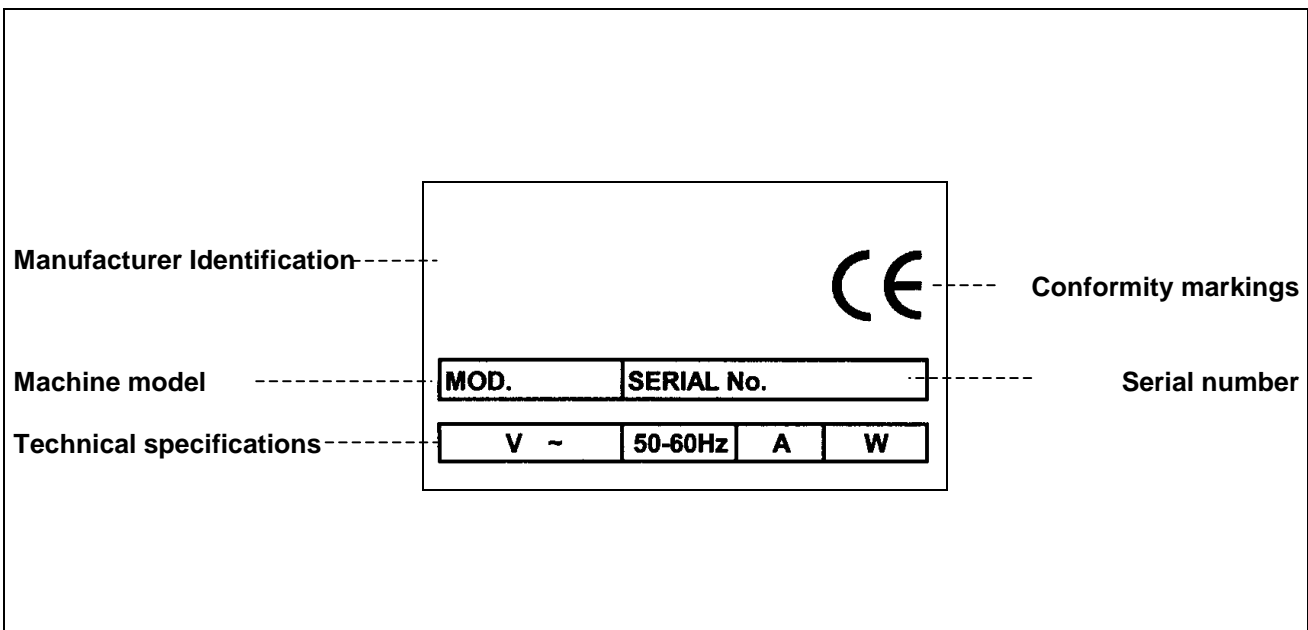

Warming surfaces with infrared lamp description

This product is specifically designed to keep the temperature of food placed over the heating surfaces constant. It is characterised by a highly simplified construction in order to reduce the possibility of malfunctions to a minimum and facilitate maintenance.

The heating surface is fully constructed with stainless steel AISI 304 18/10 with galvanized steel sheet metal bottom cover.

The resistance is attached under the heating surface.

The heating surface is distinguished by infrared lamps placed above the surface to increase its already high heating capacity.

4 rubber feet can be applied to the bottom of the heating surface for support and insulation.

Controls to turn on the machine and set temperature are found on the long side of the surface.

Technical specifications

Descriptions	Unit of measure	PCI 4711	PCI 4712	PCI 4713
Power supply	V Hz Ph	230V 50Hz 1Ph		
Nominal power	W	500	1000	1500
Net weight	Kg	10	17	25
Packaged weight	Kg	14	22	30
Installation		Counter		
Protection level		IPX4		
Electrical shock protection		Class I		
Conformity with directives and norms		73/23/EEC - 93/68/EEC - 93/44/EEC - 89/336/EEC 89/109/EEC		

Overall dimensions

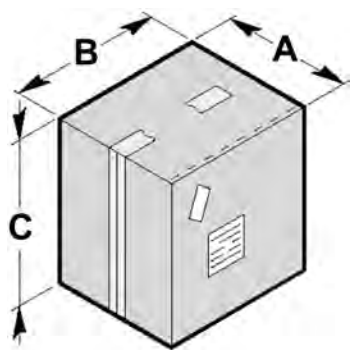
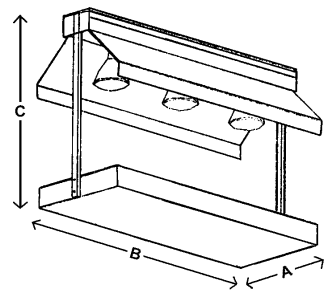
mm	A	B	C	
PCI4711	60	50	85	
PCI4712	65	85	85	
PCI4713	70	125	85	
mm	A	B	C	
PCI4711	460	510	780	
PCI4712	620	860	780	
PCI4713	620	1270	780	

Safety information

- Careful consultation of this manual before installation and use is essential. Continual observance of the indications found in the manual guarantee personal and machine safety.
- Never tamper with safety devices for any reason.
- Strict observance of the work safety regulations issued by the responsible organisations in each country is strongly recommended.
- The manufacturer is not liable for damages to persons or things due to the neglect of safety regulations.
- Correct machine placement, illumination and cleanliness are important conditions for personal safety.
- Do not expose the machine to the elements.
- Machine connections and start-up must only be performed by qualified technicians.
- Make sure that the system specifications of the room where the machine is installed correspond to the information printed on the plate.
- Make sure the machine is connected to a grounding system.
- The work area around the machine must always be kept clean and dry.
- Use the garments foreseen by work safety regulations.
- This machine must only be used for its specific purpose; any other use is considered improper and therefore hazardous.
- Do not overload the machine.
- Introducing objects, tools, hands or other within hazardous parts is forbidden.
- Keep the machine away from children.
- Disconnect the power cord from the electrical socket when the machine is not in use.
- In the event of malfunctions and/or problems, do not attempt to repair the machine. Contact the authorised dealer.
- Use original spare parts.
- Before cleaning the machine, disconnect the power supply by unplugging the machine.
- Do not clean with running water.

INSTALLATION INFORMATION 2

Packaging and unpacking

The machine is packaged in cardboard with polystyrene inserts to guarantee full integrity during transport.

- Handle the packaging according to the instructions.
- Open the packaging and check the integrity of all components. Keep packaging for future moves.
- Lift the machine as indicated and place it in the installation area.

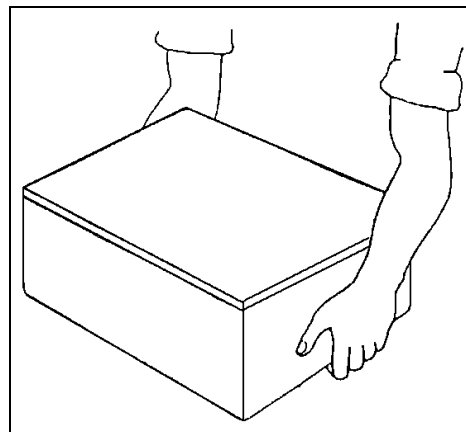

Installation area

The arranged area must be suitably illuminated and an electrical socket must be available. The resting surface must be sufficiently ample, even and dry. The machine must be installed in rooms with non-explosive environments. In any case, installation must also be performed in consideration of the work safety laws in force.

Room conditions table

Descriptions	Values
Working temperature	0÷35 °C (32÷95 °F)
Storage temperature	-15 to +65 °C (from -6.8 to +149 °F)
Relative humidity	Maximum 80% with 20 °C room temperature Maximum 50% with room temperature between 20÷60 °C
Dustiness	Less than 0.03 g/m ³

Electrical connections

⚠ DANGER – WARNING: Electrical connections to the supply mains must be performed by qualified personnel.

Verify the efficiency of the grounding system in the building. Make sure that line voltage (**V**) and frequency (**Hz**) correspond to those of the machine (See the identification plate and wiring diagram). The machine is equipped with a power cord that connects to a multi-polar plug. The plug is to be connected to a wall switch equipped with a circuit breaker.

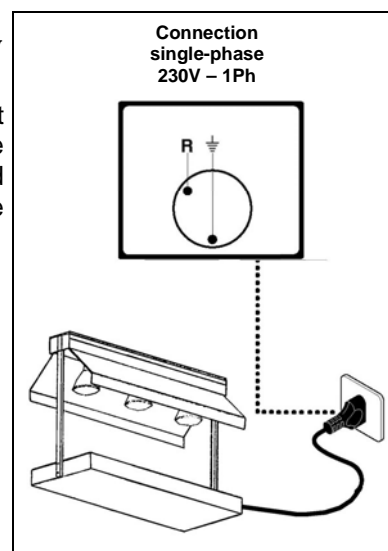

USE AND CLEANING INFORMATION **3**

Control descriptions

- Indicator light (B)
- Adjustable thermostat 0°- 90°C (C)
- Loaded circuit breaker (A) with tension led
- Power cord inlet (D) + cord

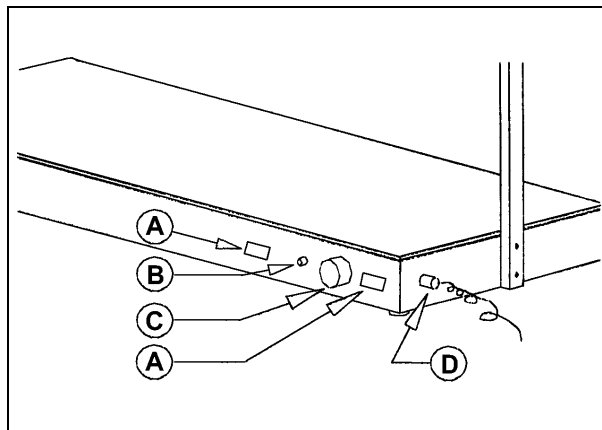

Recommendations for use

Before using the machine remove, if found, the special protective film.

Unpleasant odours produced during the first minutes of operation are due to the presence of processing grease residues.

On first use, heat the machine to the maximum temperature.

Warming surfaces with infrared lamps use

Connect the power cord to the main switch and turn the thermostat graduated knob to set the desired temperature. The led will stay on until the surface reaches the previously set temperature.

End of the day cleaning

- Remove the plug from the electrical socket at the end of the day.
- Accurately clean using neutral products.
- Clean external machine parts with a damp sponge when the machine is fully cooled.
- Do not use metallic pads and abrasive detergents.
- To avoid hazards caused by contact with high temperature parts, only access heating parts after maintenance operations have been completed.

Extended periods of disuse

For extended periods of disuse, turn off the main wall switch, clean the machine and cover it with a cloth to protect it from dust.

TROUBLE SHOOTING, RECYCLING 4

Introduction

In the event of breakdown or malfunctioning, disconnect the plug from the socket and contact your Dealer's service centre. Avoid dismantling internal machine parts.

The manufacturer is not liable for any machine tampering!

Problems, causes, solutions

Problem	Cause	Solution
The machine does not heat	Main switch off	Turn on main switch
	No voltage on the power supply	Contact your dealer's service centre
	Resistance broken	Contact your dealer's service centre

Disposal and recycling

The machine was designed and constructed to work for an average of 10.000 hours. When finished using the machine, follow national laws for disposal and recycling.

Please contact the environmental authorities or authorised organisations.