

Ficha Técnica

Cocina Serie 900 EV Cocinas con cámara de agua CHEF

Jemi Simply built to last
Professional Dishwashing and Cooking Equipment

Mod. T601 CHEF EV

Características

Dimensiones exteriores 1200 x 900 x 850 mm.

Peso 130 Kg.

Consumo gas Hi (15°C 1013,25 mbar)

Gas natural H G20 Hi = 34.02 MJ / m³ 2,53

G.P.L. G30 / G31 Hi = 45.65MJ / kg 2,05

Quemadores 2 de ø 150 mm.

4 de ø 120 mm.

Potencia quemador ø 150 mm. 8,4 Kw. / 7.200 Kcal/h.

Potencia quemador ø 120 mm. 7,4 Kw. / 6.300 Kcal/h.

Entrada gas 3/4"

Entrada agua 1/2"

Desagüe 1"

Potencia calorífica nominal 46.4 Kw.

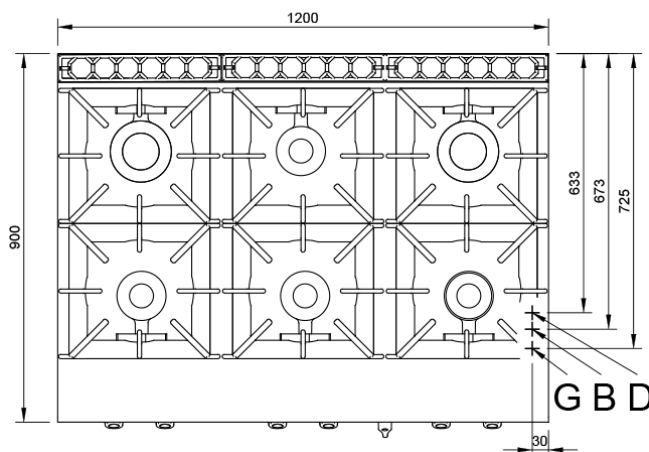
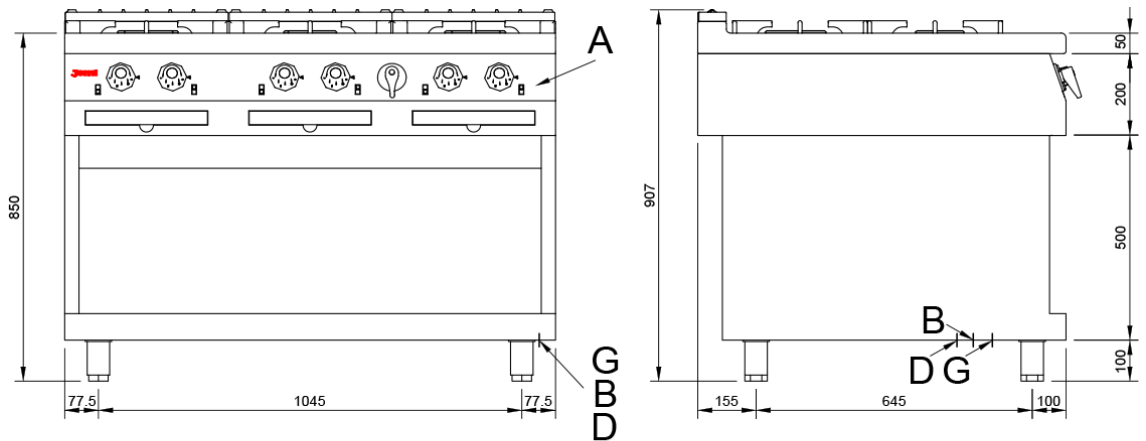

Leyenda

A. Placa de características (frontal interior)

B. Entrada agua 1/2"

D. Desagüe 1"

G. Entrada gas 3/4"

Potencia: 46,4 Kw.

39.600 Kcal/h.

