

**SOBREMESA - MUEBLE (ACEITE + AGUA)**  
**TABLETOP - FREE-STANDING (OIL + WATER)**  
**A POSER - SUR MEUBLE (HUILE + EAU)**

**FREIDORAS**  
**FRYERS**  
**FRITEUSES**

**Serie N**  
**N Series**  
**Série N**

**SOBREMESA (ACEITE + AGUA) / TABLETOP (OIL + WATER) / A POSER (HUILE + EAU)**

**Modelo**  
**Model**  
**Modèle**

**Características Characteristics Caractéristiques**

Medidas exteriores External measures Mesures extérieures (mm)	Dimensiones cesta Basket dimensions Dimensions panier (mm)	Aceite Oil Huile	Agua Water Eau	Potencia Nominal Nominal Power Puissance Nominale Kw	Voltaje (V)	Elevador Raiser Éléva- teur	Purifica- dor Purifier Purifica- teur
--	---	------------------------	----------------------	---	----------------	--------------------------------------	---

**N-7**



380 x 530 x 480	180 x 250 x 105	7	3	3,5	230 V II	-	-
-----------------	-----------------	---	---	-----	-------------	---	---

**N-7/2**



700 x 530 x 480	180 x 250 x 105	2 x 7	2 x 3	2 x 3,5	230 V II	-	-
-----------------	-----------------	-------	-------	---------	-------------	---	---

**MUEBLE (ACEITE + AGUA) / FREE-STANDING (OIL + WATER) / SUR MEUBLE (HUILE + EAU)**

**Modelo**  
**Model**  
**Modèle**

**Características Characteristics Caractéristiques**

Medidas exteriores External measures Mesures extérieures (mm)	Dimensiones cesta Basket dimensions Dimensions panier (mm)	Aceite Oil Huile	Agua Water Eau	Potencia Nominal Nominal Power Puissance Nominale Kw	Voltaje (V)	Elevador Raiser Éléva- teur	Purifica- dor Purifier Purifica- teur
--	---	------------------------	----------------------	---	----------------	--------------------------------------	---

**N-18E**



430 x 480 x 860	ø280 x 120	12	6	4	230VII 230VIII 400VIII	-	-
-----------------	------------	----	---	---	------------------------------	---	---

**N-27E**



430 x 480 x 860	ø310 x 140	17	10	5	230V 400V III	-	-
-----------------	------------	----	----	---	---------------------	---	---

**N-27**



430 x 480 x 860	ø310 x 140	17	10	5	230V 400V III	1	-
-----------------	------------	----	----	---	---------------------	---	---

**MUEBLE (ACEITE + AGUA)**  
**FREE-STANDING (OIL + WATER)**  
**SUR MEUBLE (HUILE + EAU)**

**FREIDORAS**  
**FRYERS**  
**FRITEUSES**

**Serie N**  
**N Series**  
**Série N**

**MUEBLE (ACEITE + AGUA) / FREE-STANDING (OIL + WATER) / SUR MEUBLE (HUILE + EAU)**

**Modelo**  
**Model**  
**Modèle**

**Características Characteristics Caractéristiques**

	Medidas exteriores External measures Mesures extérieures (mm)	Dimensiones cesta Basket dimensions Dimensions panier (mm)	Aceite Oil Huile	Agua Water Eau	Potencia Nominal Nominal Power Puissance Nominale Kw	Voltaje (V)	Elevador Raiser Éléva- teur	Purifica- dor Purifier Purifica- teur
<b>N-27GP</b> 	430 x 480 x 860	ø310 x 140	17	10	8	230V 400V III	1	-
<b>N-27/2</b> 	840 x 480 x 860	ø310 x 140	2 x 17	2 x 10	2 x 5	230V 400V III	1	-
<b>N-27/2GP</b> 	840 x 480 x 860	ø310 x 140	2 x 17	2 x 10	2 x 8	230V 400V III	1	-
<b>N-54</b> 	530 x 590 x 860	ø420 x 140	36	18	9,5	230V 400V III	1	-
<b>N-54GP</b> 	530 x 590 x 860	ø420 x 140	36	18	15	230V 400V III	1	-
<b>N-54/2</b> 	1080 x 590 x 860	ø420 x 140	2 x 36	2 x 18	2 x 9,5	230V 400V III	1	-
<b>N-54/2GP</b> 	1080 x 590 x 860	ø420 x 140	2 x 36	2 x 18	2 x 15	230V 400V III	1	-

# Ficha Técnica

## Freidoras Serie N Sobremesa (aceite + agua)

**Jemi** Simply built to last

Professional Dishwashing  
and Cooking Equipment

Selva de Mar, 122-128  
08020 Barcelona, España  
Tel. 0034 93 308 31 54  
Fax. 0034 93 303 38 73  
jemi@jemi.es  
www.jemi.es

### Mod. N-7 / N-7GP

#### Características

Dimensiones exteriores 380 x 530 x 480 mm.

Peso 19 Kg.

Capacidad aceite 7 litros.

Capacidad agua 3 litros.

Dimensiones cesta 180 x 250 x 105 mm.

Entrada eléctrica N-7 230V. II.

Entrada eléctrica N-7 GP 230V. III.

400V. III.

Potencia N-7 3,5 Kw.

Potencia N-7 GP 5 Kw.

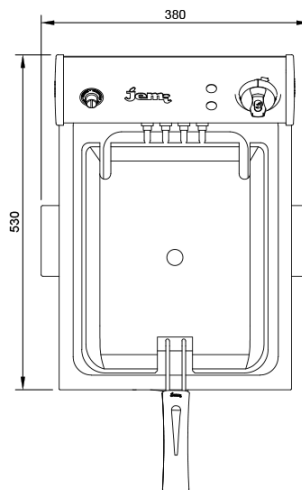
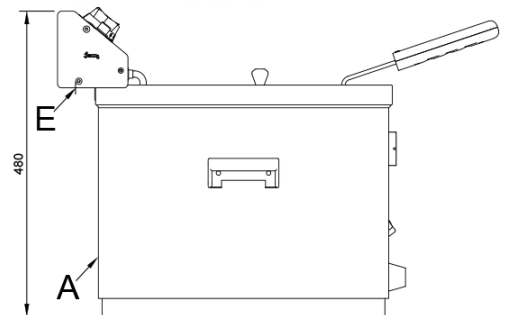
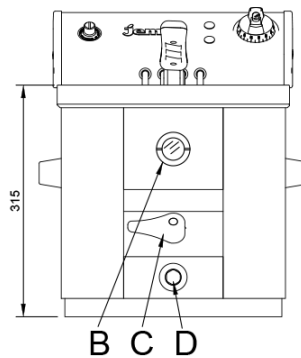

#### Leyenda

A. Placa de características  
(Parte trasera)

B Visor nivel.

C. Grifo vaciado.

D. Desagüe.

E. Entrada eléctrica: N-7 230V. II

N-7 GP 230V. III

400V. III

Potencia: N-7 3,5 Kw.

N-7 GP 5 Kw.

