

PIRA

BBQ-M150



200 comensales

- Interior en hierro fundido
- Altura regulable de la tolva del carbón
- Paredes y fondo aislados
- Parrilla extraíble
- Recogegrasas extraíble
- Cajón recogedor de cenizas
- Ruedas de nylon



ACCESORIOS INCLUIDOS

REF.	DESCRIPCIÓN
950.005	Pinzas para carne 330 mm
950.001	Atizador
901.022	Parrilla acanalada (620 x 780) x 2



ATIZADOR

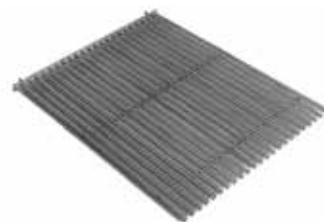

PARRILLA ACANALADA



PINZAS PARA CARNE

PIRA BBQ-M150	
REF.	160.000



INFORMACIÓN TÉCNICA

Producción media	80 Kg/h
Consumo de carbón máximo	14 Kg por servicio
Tiempo de encendido	30 min.
Temperatura de trabajo	de 180°C a 350°C
Peso neto	410 Kg
Potencia Equivalente	7.0 KW

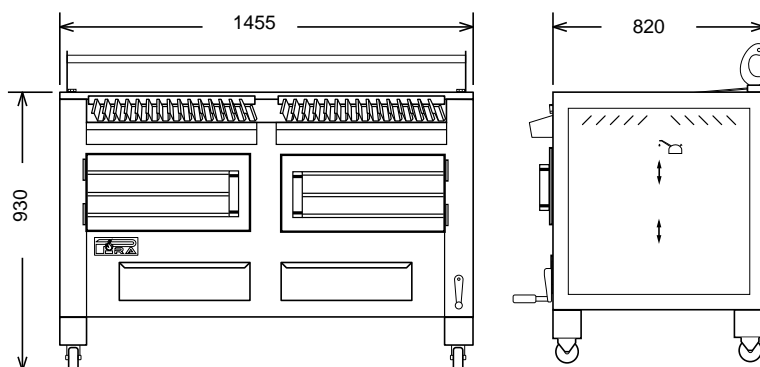

ACCESORIOS

REF.	DESCRIPCIÓN
900.022	Parrilla varilla (620 x 730)
901.024	Plancha (620 x 780)
900.222	1/2 Parrilla varilla (310 x 730)
901.222	1/2 Parrilla acanalada (310 x 780)
901.224	1/2 Plancha (310 x 780)
904.000	Asador (1300 x 320)
904.001	Kit soporte asador
904.002	Asa auxiliar

ACCESORIOS

REF.	DESCRIPCIÓN
902.044	Soporte paellero (620 x 730)
905.001	Kit soporte pinchos
905.000	Pincho
920.150	Columna Calientaplatos BBQ 150
920.322	Parrilla Calientaplatos BBQ 150
905.003	Pala carbón
909.050	Mesa lateral inox (810 x 350)
909.000	Mesa lateral negra (810 x 350)
950.004	Pinzas para carne TOP 400 mm



PARRILLA VARILLAS

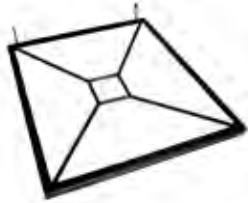

SOPORTE PAELLERO



ASA AUXILIAR

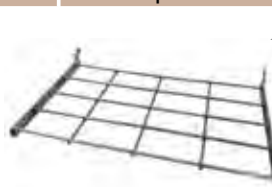

PARRILLA CALIENTAPLATOS

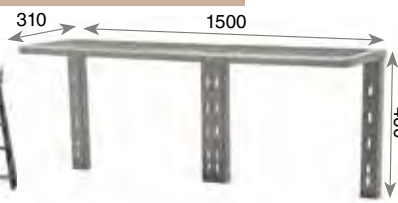

COLUMNA CALIENTAPLATOS

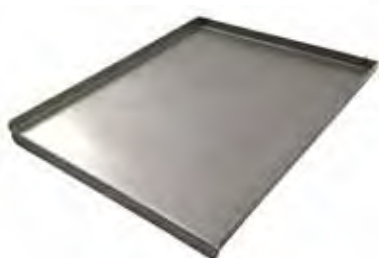

PLANCHA



ASADOR



KIT SOPORTE ASADOR



KIT SOPORTE PINCHOS



PINCHO



MESA LATERAL INOX



1/2 PARRILLA ACANALADA



1/2 PARRILLA VARILLA



1/2 PLANCHA

