

# PIRA

## 120 SILVER



175 comensales

- Interior en hierro fundido
- Sistema refrigerante Piracold®
- 7 guías
- Cajón recogedor de cenizas
- Cortallamas integrado
- Termómetro
- Regulador de tiro integrado
- Recogedor de aceites integrado



*Chef Andrea Ramezzana, italian assessor chef en Host Milano 2019*

### PIRA 120 SILVER SD

REF. 120.106



### PIRA 120 SILVER ED

REF. 120.107



### INFORMACIÓN TÉCNICA

Producción Media	150 Kg/h	Capacidad bandejas GN por parrilla	3xGN 1/1
Carga máxima de carbón	6 Kg	Salida humos	210 mm
Consumo de Carbón (máx)	7 Kg por servicio	Peso neto	360Kg
Tiempo de encendido	30 min.	Peso neto ED	391 Kg
Temperatura de Trabajo	de 180°C a 350°C	Potencia Equivalente	8.0 KW

### MEDIDAS PIRA 120 SILVER SD

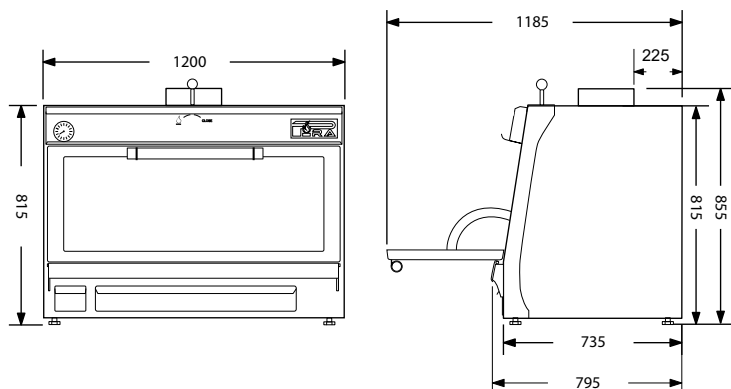

### MEDIDAS PIRA 120 SILVER ED

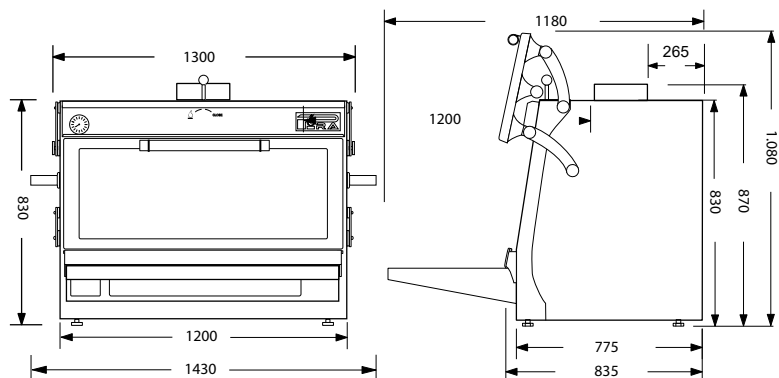

## ACCESORIOS INCLUIDOS

REF.	DESCRIPCIÓN
950.004	Pinzas para carne TOP 400 mm
950.008	Atizador
900.120	Parrilla varilla 120 (1060x625)
904.012	Mesa Frontal Inox 40 cm 120 ED



PARRILLA VARILLA



PINZAS PARA CARNE TOP 400 MM



ATIZADOR



MESA FRONTAL INOX 40 CM



## ACCESORIOS

REF.	DESCRIPCIÓN
750.007	Cortallamas Externo* 120
750.008	Sombrero Inox 120
*Kit Chimenea con Cortallamas externo obligatorio. Info pag 42/43	
901.120	Parrilla acanalada 120 (990x625)
965.120	Soporte pinchos 120 (capacidad 15 u.)
965.021	Soporte pinchos Pollo 120 (capacidad 5 u.)
961.120	1/2 Lámina para pizzas 120 (520x590)
970.120	Separador 120 4 guías
970.122	Separador 120 6 guías
900.122	1/2 Parrilla varilla 120 (535x625)
901.122	1/2 Parrilla acanalada 120 (460x585)
960.122	1/2 Plancha 120 (458x590)
965.122	1/2 Soporte pinchos 120 (capacidad 6u.)
955.090	Pinchos 90/120
955.120	Pinchos Pollo 90/120
950.005	Pinzas para carne 330 mm
920.120	Bandeja Calientaplatos 120
924.120	Bandeja Calientaplatos 120 ED
902.912	Mesa Frontal 29 cm 120 ED
770.220	Mesa Carbonera Pira 120
770.320	Mesa Carbonera Pira 120 SILVER



PARRILLA ACANALADA



1/2 PLANCHA



SOPORTE PINCHOS



SOPORTE PINCHOS POLLO

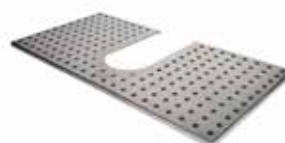

BANDEJA CALIENTAPLATOS



SEPARADOR 120 (4 GUIAS)

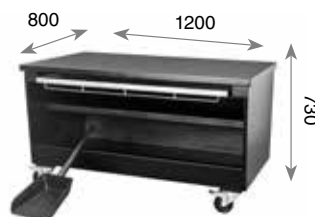

MESA CARBONERA PIRA 120



MESA CARBONERA PIRA 120 SILVER



1/2 LÁMINA PARA PIZZAS 120



PINZAS PARA CARNE 330 MM